

GHG-RT Concealed Torque Hinge

Features

- Hinge with friction torque holds lid / door in desired position
- Hinge is completely hidden when the door is closed
- Torque decreases as the opening angle increases, making it easier to open the lid (refer to "Torque Curve")
- Use with top-opening lids (free stop range operating angles 0° ~ 100°)
- Passed 20,000 life cycle test

Notes

- Operating temperature: 0°C ~ 40°C
- During selection, ensure that the maximum torque of lid (door) is less than half of the torque at the hinge closed position (see below table)
- Use a stopper for portions outside free stop / torque range
- Ensure both hinge shafts are levelled and aligned during installation

Recommended Screws

- Countersunk head tapping screw 4 or Countersunk head screw M4

Torque Curve

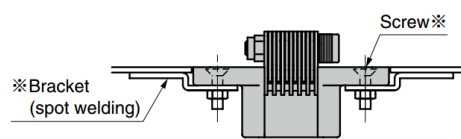
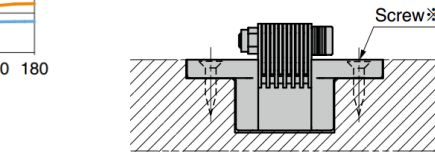
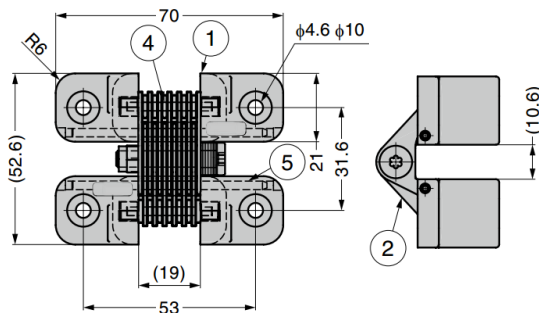
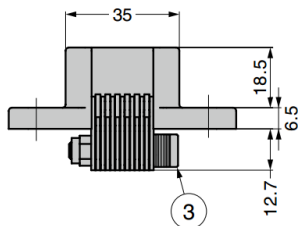
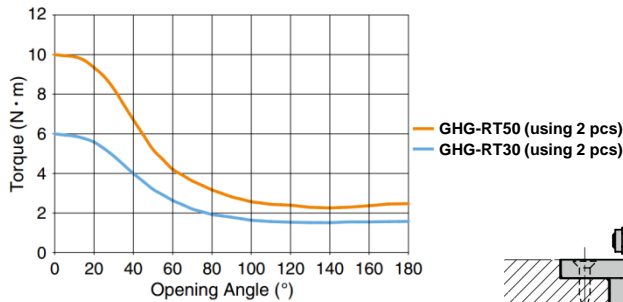

※Screws and brackets not included.

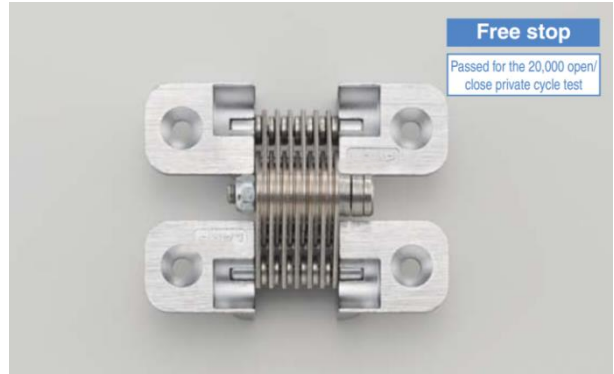
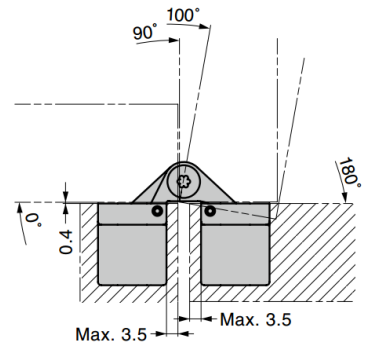

Application Example

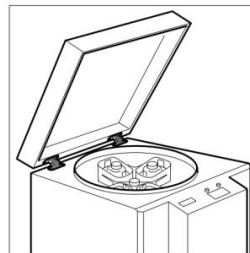

Use with top-opening lids (opening angle 0° ~ 100°).

Free Stop Range

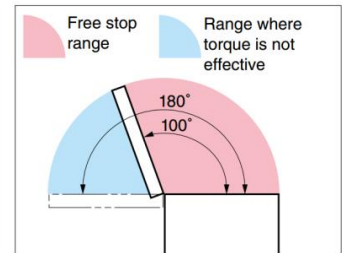

Install stopper to hold the door within the range where torque is not effective.

No.	Part Name	Material	Finish
①	Body	Zinc Alloy (ZDC)	Satin Chrome
②	Arm	Stainless Steel (SUS304)	Plain
③	Shaft 1		
④	Shaft 2		
⑤	Shaft 3		

Part No.	Opening Angle	Max. Lid Moment (per pair)		Torque (Closed Position) (per pair)	
GHG-RT30	180°	3 N.m	31 kgf.cm	3 ±20% N.m	31 ±20% kgf.cm
GHG-RT50		5 N.m	51 kgf.cm	5 ±20% N.m	51 ±20% kgf.cm